

# Operating instructions

## Sediplus<sup>®</sup> S 200

SARSTEDT Item No. 90.189.900



CE

---

Document information

---

Version: V 3.2  
Created on: 16042009  
Valid from machine version: S 200 V 01.03  
File: BA-S200-E 16042009.DOC

---

**Table of contents**

---

	Page
1. Machine data .....	4
2. Manufacturer's address .....	4
3. Important notes .....	4
Explanation of symbols .....	5
Device-specific safety notes .....	5
Obligation of the operator .....	6
Obligation of the personnel .....	6
4. Additional notes .....	6
Warranty and liability .....	6
Decommissioning / Disposal .....	7
5. Description of the device .....	7
6. Transport, assembly and connection .....	7
Scope of delivery .....	7
Unpacking .....	8
Technical data .....	8
Set-up .....	9
Commissioning .....	9
7. Operation .....	10
Operating elements .....	10
Preparation of the samples .....	11
Inserting the SARSTEDT S-Sedivettes .....	12
Conducting the measurement .....	12
Data storage .....	15
Measurement values .....	18
Examples of technical literature .....	19
8. LIS / Printer connection .....	20
9. Device configuration .....	23
10. Maintenance and repair .....	25
Cleaning .....	25
Maintenance intervals .....	25
Simple functional checks by the user .....	26
Troubleshooting .....	27
Service address .....	28
11. Glossary .....	29
Contamination questionnaire .....	30

---

## 1. Machine data

(to be completed by the customer)

Type: \_\_\_\_\_

\_\_\_\_\_

Serial no.: \_\_\_\_\_

Location: \_\_\_\_\_

Date: \_\_\_\_\_

Inventory no.: \_\_\_\_\_

---

## 2. Manufacturer's address

SARSTEDT AG & Co.  
PO Box 1220  
D-51582 Nümbrecht

Telephone: +49 (0) 22 93 / 305 0  
Fax: +49 (0) 22 93 / 305 282  
email: [info@sarstedt.com](mailto:info@sarstedt.com)

---

## 3. Important notes

**Prior to commissioning the device, observe the safety notes in these operating instructions!**

A basic prerequisite for the proper handling and correct operation of the device is familiarity with the contents of these operating instructions.

**Please keep these operating instructions as fundamental information for your device.**

### Copyright:

SARSTEDT-AG & Co. has the copyright of the present operating instructions. The operating instructions are only intended for the operating personnel and the purchaser of the device. These operating instructions may not be duplicated nor distributed in part or in full without the written consent of SARSTEDT AG & Co.

Non-compliance may be punishable by law.

**SARSTEDT S-Sedivette® and Sediplus® S 200 are registered trademarks of SARSTEDT AG & Co.**

**Technical changes reserved!**

Nümbrecht, May 2008

**SARSTEDT AG & Co.**

---

## Explanation of symbols

---

These operating instructions contain the following important symbols in order to indicate dangers and operating errors.



The "Attention" sign means that in this section:

- Important notes are given.
- An immediate or potentially health or life-threatening danger is described.
- A note regarding dangerous situations can be found.

**Disregard of this symbol can result in minor to severe or even life-threatening injuries, or property damage.**



The high voltage symbol means:

**Warning of dangerous, electric current!**



This "Info symbol" gives advice for the proper handling of the device or gives general information for better understanding. Disregard of the notes can lead to defective operation or even damage to the device.

Additional symbols contain notes for the theme represented in the symbol, like accident prevention guidelines, power supply, maintenance, or disposal.



The warning symbol means:

**Warning of irritants or materials that are harmful to your health!**

- Disregard of this symbol can lead to severe damage to your health.
- Constantly observe applicable accident prevention guidelines when handling these materials.

---

## Device-specific safety notes

---



This device is built state-of-the-art and according to the recognised technical safety regulations.

The applicable safety notes and guidelines, as well as work safety and accident prevention guidelines for application in a laboratory must be observed.

Nevertheless, dangers for the user, for third parties, and/or disturbances on the device or other material assets may arise during operation.

The device may only be used:

- for the designated use.
- in technically-sound, properly-functioning condition.

The device may not be operated in potentially explosive areas.

The device conforms to international safety regulations.



The device is operated through an external power supply with a voltage of 12V DC. The following notes must be adhered to without fail:

- No water or other fluids may penetrate into the equipment.
- Only the supplied wall plug transformer may be used for connecting the device to the network.
- Check the connecting cable for damage before commissioning. Damaged cables should not be used in any case.



The device should only be operated or completed with accessories that are expressly intended for it.

The manufacturer recommends inspection of the device at intervals of two years, in accordance with the applicable accident prevention guidelines (repeated inspection of electrical equipment).

---

### Obligation of the operator

---

The operator of the device is obligated to only assign work on the device to personnel that have read and understand these operating instructions. This should be confirmed by their signature. Personnel should be checked periodically to ensure regular working within safety guidelines.

---

### Obligation of the personnel

---

Persons working with the device for the first time are obligated, prior to commissioning:

- To read through these operating instructions.
- To observe the applicable regulations and the guidelines for accident prevention.

---

## 4. Additional notes

---

---

### Warranty and liability

---

In principal, the “*Terms of delivery and payment*” of SARSTEDT AG & Co. apply. These are noted on the back-side of the invoice.

During the warranty period, the device may only be repaired by SARSTEDT AG & Co. or by persons authorised by SARSTEDT AG & Co.

With improper handling or repair, any warranty claims expire.

Warranty and liability claims are excluded if they result from one or more of the following causes:

- Improper use of the device.
- Improper assembly, commissioning, operation, or maintenance of the device.
- Operation of the device with defective safety equipment, improperly attached, or non-functional safety and protective devices.
- Non-adherence to the notes from the operating instructions in regard to transport, storage, assembly, commissioning, operating, maintenance, set-up, and disposal.
- Arbitrary changes to the device.
- Disaster situations through impact of foreign objects and higher powers.
- Improperly performed repairs.

---

## Decommissioning / disposal

---



- The device must be handled and disposed of competently and properly in accordance with the applicable regulations.
- The substances that are used and/or introduced in combination with this device must be handled and disposed of competently and in accordance with the applicable regulations.



These operating instructions consist of the following materials:  
The cover consists of PVC, the rest of paper.

---

## 5. Description of the device

---

The 10-channel blood sedimentation measuring device Sediplus® S 200 is based on the extensive experience of SARSTEDT in the area of blood sedimentation. Through the use of the most modern micro-controller technology, automatic, easy-to-operate blood sedimentation is available in the Sediplus® S 200.

The sedimentation values measured in the SARSTEDT S-Sedivette® are converted by the device into Westergren values. The user continues to work with the customary data.

Using the Sediplus® S 200, either 10 sedimentations can be measured simultaneously or independently from one another. Ongoing checks by the built-in micro-controller ensure the optimal functioning of the measurement system.

During power failure the automatic data storages saves the measurement values that have already been calculated.

No battery is necessary for data protection.

---

## 6. Transport, assembly and connection

---



---

### Scope of delivery

---

#### Standard scope of delivery

90.189.900	Sediplus® S 200 incl. Mains adapter 12V DC, 1.25A, negative pole earthed Mains cable
------------	--

#### Accessories / spare parts:

92.189.910	Mains adapter 12V DC, 1.25A, negative pole earthed
92.189.911	Mains cable
92.189.915	SediTest S 200
92.189.930	Barcode reader with wedge interface for S 200
92.189.935	IBM keyboard with PS/2 plug
90.189.720	Thermal printer with mains adapter 230/6
90.189.750	Sediplus® Data-Manager
90.180.700	Sarmix® M 200 (for 4 S-Sedivettes)
90.180.600	Sarmix® M2000 (Mixer for S-Sedivette®)
92.180.615	Block rotor for M 2000 (for 40 S-Sedivettes)

Should you have questions regarding additional SARSTEDT BSS machines or the SARSTEDT product range, please contact:

**SARSTEDT AG & Co.**  
**PO Box 1220**  
**D-51582 Nümbrecht**

**Telephone: +49 (0) 22 93 / 305 0**  
**Fax: +49 (0) 22 93 / 305 282**

or your local SARSTEDT seller in connection.

---

## Unpacking

---



- Check the integrity of the packaging carton and the device.
- Immediately inform the carrier of transport damage! Observe the notification period of the individual transport companies (rail, post, parcel service or carrier). Owing to circumstances it is only 24 hours.
- Check scope of delivery.
- Defects and damages must be reported immediately to SARSTEDT AG & Co.!

---

## Technical data

---

### Device data

Device:	Sediplus® S 200
Manufacturer	SARSTEDT AG & Co.
Order number:	90.189.900
Measuring principle:	Reflection measurement IR 880 nm
Measuring method:	Measurement in the blood sedimentation device Sediplus® S 200 in combination with the SARSTEDT S-Sedivettes
Measurement range:	0-63 mm absolute (=0-109 mm Westergren)
Measurement precision:	± 1 mm of the measured displacement
Display:	16-digit LC display with 9 mm character height Lapsed measurement time in the form h:mm:ss Measurement value in mm (according to Westergren for 1h and 2h) 10 3-colour LEDs for status indication of the measurement channels.
Interfaces:	RS232 for EDV connection or serial printer PS/2 connection for IBM keyboard and /or barcode reader.

### Supply

Electrical connection:	Mains plug with connector for non-heating apparatus: Input voltage: 100V~ – 240V~ 50/60 Hz 12V DC 1,25A; negative pole earthed. short circuit protected
Active output:	15 W maximum
Fuse:	None

### Ambient conditions

Allowable ambient temperature:	Working temperature (18°C to 23°C), or according country- or laboratory specific standards
Maximum relative humidity:	80 % not condensing

### Dimensions

Width x depth x height:	300 mm x 300 mm x 160 mm
Weight:	2.6 kg without mains adapter



**Set-up**

Because the BSS can be influenced by numerous sources of error, the following should be observed when setting up the machine:



- Place the machine on a solid, vibration-free and even surface. The machine must be set up vertically because an inclined position can lead to incorrect sedimentation results.
- Deviations from working temperature (see technical data) can lead to changes of the sedimentation results. Therefore the machine should not be set up in the vicinity of radiators or other sources of heat.
- Direct solar radiation or light radiation from the front or from the side must be avoided.
- Always keep the measurement lens clean. In particular, blood or plasma spatter should not get into the lens.

**Commissioning**



**Attention with the initial start-up!**

- Through the use of the mains adapter (100V~ – 240V~) the machine has a wide range of operation independent of the available mains voltage. Nevertheless, ensure that your mains supply lies within the indicated range.
- Observe permissible ambient conditions for the device. (see Page 8 Ambient conditions)
- During the cold season, after delivery and unpacking, wait approx. 30 to 45 minutes until the device has assimilated to working temperature (see technical data).

Insert the round plug of the mains adapter into the device socket on the back side of the Sediplus® S 200.

The On / Off switch is likewise located on the back side of the device.

After switching on, the device carries out internal checks and initialisations. During this time all LEDs are energised in the 3 different colours: green, red, and orange. The following text appears in the display:

				S	A	R	S	T	E	D	T				
--	--	--	--	---	---	---	---	---	---	---	---	--	--	--	--

After completion of the initialisation the following text is displayed:

	S	2	0	0		V	x	x	.	y	y				
--	---	---	---	---	--	---	---	---	---	---	---	--	--	--	--

xx.yy = current firmware version number e.g.: 01.00

At this point in time 1 or more of the LEDs may illuminate.

The following colours are possible:

- Green LED: An applicable measurement value is present in the corresponding channel, which can be displayed by pressing the channel button.
- Red blinking LED: An ongoing measurement was interrupted in this channel by a power failure (see error messages).

## 7. Operation

### Operating elements

The operation of the Sediplus® S 200 takes place interactively. The following input and/or output elements are available to the user for this:

<b>Input</b>	Buttons 1 – 10 START button ESC button
<b>Output</b>	Optional barcode reader and/or keyboard LC-Display 16-digit 3-colour LED per channel Acoustic signaller

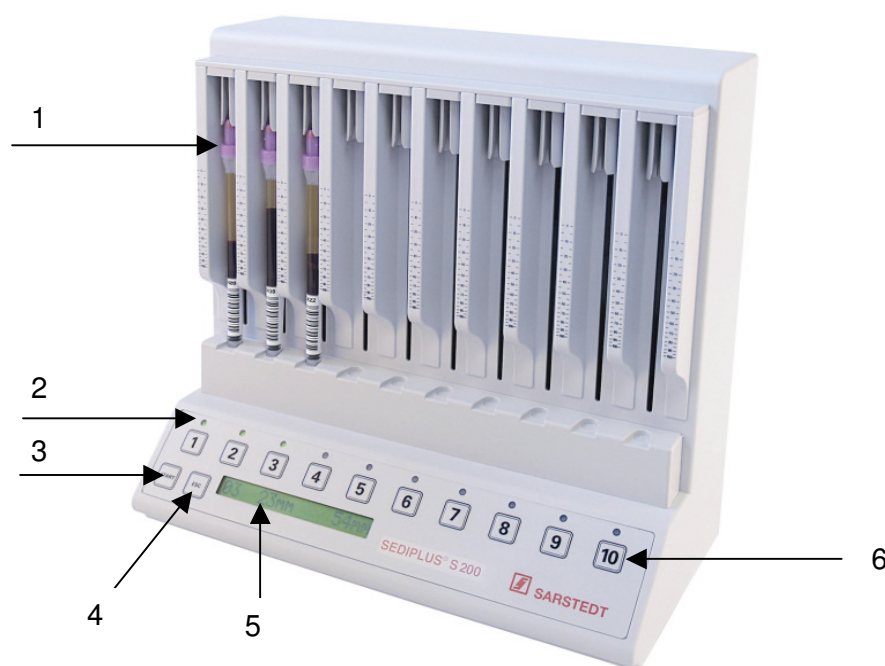

Index	Description	Index	Description
1	Loading position (channel)	6	Channel buttons [1] .. [10]
2	Channel status LED	7	On/off switch
3	[START] button	8	Socket for mains plug
4	[ESC] button	9	EDV connection SUBD socket 9pole.
5	16-digit LC display	10	Connection for keyboard and/or barcode reader

---

**Preparation of the samples**

---



- Only use the SARSTEDT S-Sedivette®.
- Observe the notes for handling on the packaging of the SARSTEDT S-Sedivette®.
- The surface of the S-Sedivette® must be clean. No residue from labels or traces of powder from gloves may be on them. Additional signals that arise from impurities are registered and can considerably influence the evaluation of the sedimentation. The original label or a label affixed at the same height will not disrupt the measurement.
- While inserting the S-Sedivette® no droplets of blood should be in the cap, and the cone of the S-Sedivette® should not be wet. The measurement could be falsified by blood dripping down.
- The samples should not be moved directly from the refrigerator and placed in the S 200 for analysis. For the accuracy of the results it is crucial that the samples are always at working temperature (see technical data).
- No blood or plasma spatter should get onto the measurement lens.
- If your own label is applied, it must be ensured that it is not affixed significantly higher than the original label of the S-Sedivette®. Your own label may be applied a maximum of 6 mm above the original label.  
A label that is applied too high will lead to an error message and the interruption of the measurement.

The blood sample is conducted with the SARSTEDT S-Sedivette® with sodium citrate solution as an anticoagulant. The S-Sedivette® is a closed blood sampling system that simultaneously serves as a sedimentation tube. You do not have to transfer blood or fill a separate pipette.



- Every blood sample must be thoroughly mixed immediately after extraction and immediately before inserting into the device, but without creating foam.
- Use the obtained blood sample as soon as possible. If the sample is stored at room temperature, the analysis should be conducted within 4 hours. The blood sample should not have coagulated.

## Inserting the SARSTEDT S-Sedivettes



- The S-Sedivettes must be correctly filled for the blood sedimentation. For this it must already be ensured during the blood extraction that the SARSTEDT S-Sedivettes are handled according to the handling notes on the packaging.
- The S-Sedivettes are filled correctly if the plunger is pulled out to the "snap position".
- With an underfilling it is up to the operator's discretion whether the BSS values must be doubted.
- The blood volume in the Sedivette column influences the sedimentation value.

Insert the SARSTEDT S-Sedivette® as shown in the drawings below. For organisational reasons, however, it is generally advisable to place the first sample in the first measuring point, the second sample in the second measuring point, etc; this means that the 11th sample should be placed in the first measuring point. In doing so it is irrelevant in what time intervals the measurements are started, because the time counting for each measuring point takes place separately and the samples are measured completely independently of one another.

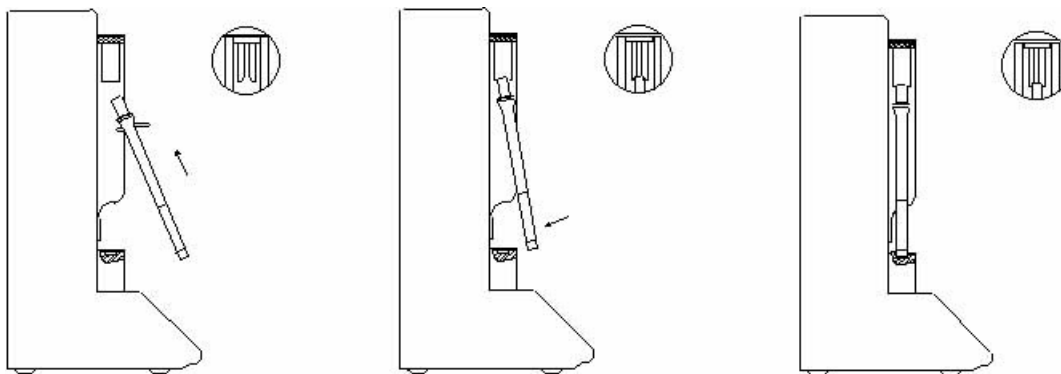

In order to avoid wrong signals on the measurement lens from the labels attached to the S-Sedivette®, you should make sure that any gap between the ends of the label face toward the user after inserting the S-Sedivette®.

## Conducting the measurement

### ID Number

After the sample is placed in the measuring point the measurement can begin. For identification of the measurement an ID number is assigned to it. The ID number involves a 12-digit character string which can be entered in 2 different ways.

#### 1. Auto-ID

The device assigns an automatic ID number that is increased by one for each measurement. The last-used Auto-ID remains saved even after switching off the device. After switching back on, the next start of a measurement is continued with the last used Auto-ID + 1.

For resetting the Auto-ID, see "Starting the measurement".

## 2. Input through barcode reader, or keyboard

The ID number can be entered by reading off through an optional barcode reader or an IBM keyboard with PS/2 plug.

A max. 12-digit alphanumeric barcode is accepted.

The barcode reader must be prepared so that it ends with the characters read off with CRLF. See the user's guide of the barcode reader.

The following characters can be entered by the keyboard:

- All characters between ASCII code 32 and 127 (decimal), the button [←] for entry corrections, and the button [ENTER].



For differentiating between an Auto-ID and a numeric barcode, the Auto-ID number is always filled out with the most prominent 0 to 12 positions, whereas with entry through the keyboard or barcode reader, the most prominent blank characters are filled out in 12 positions.

### Starting the measurement

- Place the sample in the desired remaining available position (channels).  
If all channels are available, their LEDs either do not illuminate, illuminate in the colour green, or blink red after power failure.
- Press the button [START].  
The device issues an Auto-ID to the measurement and prompts the user to start the measurement in the desired channel by pressing a channel button (1-10). A continuous tone is released by the internal signaller and the following display appears (in the example Auto-ID = 17)

0	0	0	0	0	0	0	0	0	0	1	7		C	.	?
---	---	---	---	---	---	---	---	---	---	---	---	--	---	---	---

You now have 10 seconds to react to the prompt described as follows:

- Interrupt by pressing the [START] button again.  
An interruption also cancels a previous resetting of the Auto-ID!
- Resetting the Auto-ID to the value 000000000001 by pressing the [ESC] button.
- Overwriting the Auto-ID by reading off a barcode, or entry through a keyboard.
- Conclusively starting the measurement by pressing the channel button that is assigned to the position in which the sample was placed.

If the start of the measurement does not take place within 10 seconds, the starting process is interrupted.



#### ATTENTION:

Resetting the Auto-ID to the value 000000000001 **does not delete** any measurement results already saved.

Be careful when resetting the Auto-ID in order to avoid double allocations of ID numbers. An inadvertent reset can be undone with [START]!

If you are not working with your own ID numbers (barcodes) then there is no reason to reset the Auto-ID, unless you would like to begin the ID numbers on each work day with 000000000001.

Writing over the Auto-ID with a barcode reader or keyboard does not change the value of the previous Auto-ID.

The Auto-ID reaches the maximum value of 000000999999. 000000000001 is given again as the next number.

**Process of the measurement**

After successfully starting the measurement the samples to be measured are scanned in the following listed intervals:

Time point	Function																
immediately	<p>Check of the following criteria:</p> <ul style="list-style-type: none"> <li>- Sample present ?</li> <li>- Sample over-filled ?</li> <li>- Sample under-filled ?</li> <li>- Label affixed too high ?</li> </ul> <p>The measuring time for the current channel begins to run                      The <b>LED</b> of the current channel illuminates <b>red</b>.                      During the on/off movement of the measuring head this display appears:</p> <table border="1" style="width: 100%; text-align: center;"> <tr> <td>C</td><td>h</td><td>a</td><td>n</td><td>n</td><td>e</td><td>l</td><td></td><td>1</td><td></td><td>S</td><td>t</td><td>a</td><td>r</td><td>t</td><td></td> </tr> </table>	C	h	a	n	n	e	l		1		S	t	a	r	t	
C	h	a	n	n	e	l		1		S	t	a	r	t			
after 30 sec	<p>Fill level of the sample.                      The value determined here applies as the starting point (zero point) for the additional measurements of the 1h value, and/or the 2h value.                      Within these 30 sec. blood droplets can manage to run out of the screw cap and yield a different fill level than was the case during the 1<sup>st</sup> measurement.                      The <b>LED</b> of the current channel illuminates <b>red</b>:</p> <table border="1" style="width: 100%; text-align: center;"> <tr> <td>C</td><td>h</td><td>a</td><td>n</td><td>n</td><td>e</td><td>l</td><td></td><td>1</td><td></td><td>O</td><td>f</td><td>f</td><td>s</td><td>e</td><td>t</td> </tr> </table>	C	h	a	n	n	e	l		1		O	f	f	s	e	t
C	h	a	n	n	e	l		1		O	f	f	s	e	t		
after 60 min	<p>Evaluation of the 1h value                      The <b>LED</b> of the current channel illuminates <b>orange</b>                      Display:</p> <table border="1" style="width: 100%; text-align: center;"> <tr> <td>C</td><td>h</td><td>a</td><td>n</td><td>n</td><td>e</td><td>l</td><td></td><td>1</td><td></td><td>1</td><td>h</td><td></td><td></td><td></td><td></td> </tr> </table>	C	h	a	n	n	e	l		1		1	h				
C	h	a	n	n	e	l		1		1	h						
after 120 min	<p>Evaluation of the 2h value                      The <b>LED</b> of the current channel illuminates <b>green</b>                      During the on/off movement of the measuring head this display appears:</p> <table border="1" style="width: 100%; text-align: center;"> <tr> <td>C</td><td>h</td><td>a</td><td>n</td><td>n</td><td>e</td><td>l</td><td></td><td>1</td><td></td><td>2</td><td>h</td><td></td><td></td><td></td><td></td> </tr> </table>	C	h	a	n	n	e	l		1		2	h				
C	h	a	n	n	e	l		1		2	h						

During the measurement the process status for each channel can be called up individually. To do so, press the desired channel button. One of the following listed readouts appears in the display.

**During the 1<sup>st</sup> hour of the measurement**

Channel number (here 1) and the lapsed measuring time (here 0:17:32 hours)

0	1			0	:	1	7	:	3	2				
---	---	--	--	---	---	---	---	---	---	---	--	--	--	--

**During the 2<sup>nd</sup> hour of the measurement**

Channel number (here 1), sedimentation value after 1 h (here 2 mm) and lapsed measuring time (here 1:22:10 hours)

0	1				2	m	m		1	:	2	2	:	1	0
---	---	--	--	--	---	---	---	--	---	---	---	---	---	---	---

**After the end of the measuring time**

Channel number (here 1), sedimentation value after 1h (here 2 mm) and after 2 h (here 5 mm)

0	1				2	m	m							5	m	m
---	---	--	--	--	---	---	---	--	--	--	--	--	--	---	---	---

**Interruption of a measurement in progress**

A measurement in progress can be interrupted by the user at any time. In order to interrupt a measurement, proceed as follows:

Press the desired channel button (in the example Channel 6).  
 One of the status displays shown above appears.  
 Press the [ESC] button  
 The following display appears, which prompts you to confirm the procedure.

0	6				I	n	t	e	r	r	u	p	t		?	
---	---	--	--	--	---	---	---	---	---	---	---	---	---	--	---	--

The following reactions are possible:  
 [ESC] button: The measurement is **not** interrupted  
 [START] button The measurement of the selected channel is interrupted

**Data storage**

The SARSTEDT Sediplus® S 200 is equipped with a NV-RAM memory whose content is not lost after switching off the power supply. The following data is saved in this memory.



- All configuration data
- The data of the measurements in progress of all channels
- The measurement results of a max. 125 samples  
 The measurement results remain saved until they are called up by an EDV system or a serial printer. Measurement results that are called up are deleted from the memory.  
 If no measurement results are called up, then the oldest results are overwritten according to the FIFO principle, as soon as the data storage is full.

Display of the last measurements of the individual measuring channels

Only the last measurement results of a measuring channel can be shown on the display of the Sediplus® S 200. A green LED signals that a result is available in a measuring channel.

**This result can also be an error message!**

It is available until a new measurement is started in this channel or the last result of a channel is manually deleted.

By pressing the desired channel button the following information is displayed:

- **ID number of the measurement**

Press the channel button. As long as the button is pressed and held, the channel number (left-aligned) and ID number (right-aligned) of the measurement are displayed.

Here Channel 1 ID Number *Sample ID* (Entry through keyboard)

0	1					S	a	m	p	l	e	-	I	D
---	---	--	--	--	--	---	---	---	---	---	---	---	---	---

- **Current status of the measurement, or last result of the measurement**

After releasing the channel button the display changes as follows:

Depending on whether a measurement is already running in the selected channel or results are already available, either the current process status or the result of the last measurement is displayed.

0	1			0	:	1	7	:	3	2				
---	---	--	--	---	---	---	---	---	---	---	--	--	--	--

0	1			2	m	m		1	:	2	2	:	1	0
---	---	--	--	---	---	---	--	---	---	---	---	---	---	---

0	1			2	m	m							5	m	m
---	---	--	--	---	---	---	--	--	--	--	--	--	---	---	---

0	2			5	7	m	m			>	1	1	0	m	m
---	---	--	--	---	---	---	---	--	--	---	---	---	---	---	---

0	3			7	2	m	m						N	P	!
---	---	--	--	---	---	---	---	--	--	--	--	--	---	---	---

0	4			N	P	!							7	5	m	m
---	---	--	--	---	---	---	--	--	--	--	--	--	---	---	---	---

0	5			N	P	!							N	P	!
---	---	--	--	---	---	---	--	--	--	--	--	--	---	---	---





**Special cases:**

The following exceptions have a special meaning:

- **>110mm**  
This value is given if a clear sedimentation value of more than 110 mm was recognised. This sedimentation applies as “accomplished”.
- **NP! (not plausible)**  
This value is given if no clear sedimentation value was recognised or the recognised transfer appears implausible. Therefore it could be that the 1h value is identified as implausible or unclear, but the 2h value was clearly recognised.

**Manual deletion of the last results of an individual measuring channel**

- Select the desired channel by pressing a channel button (here Channel 6)
- Press the button [ESC]. You will be prompted to confirm the process through the following display

0	6					D	e	l	e	t	e	?		
---	---	--	--	--	--	---	---	---	---	---	---	---	--	--

The following reactions are possible:

- [ESC] button:                      The last result from Channel 6 is **not** deleted.
- [START] button                      The last result from Channel 6 is deleted.

**Manual deletion of the last results of all channels**

- Simultaneously press the buttons [START] and [ESC]  
You will be prompted to confirm the process through the following display:

D	e	l	e	t	e		c	h	a	n	n	e	l	s	?
---	---	---	---	---	---	--	---	---	---	---	---	---	---	---	---

The following reactions are possible:

- [ESC] button:                      Nothing is deleted.
- [START] button                      The results of all channels are deleted.



**IMPORTANT:**

Even if the last measurement result of a channel no longer appears in the display because of a new measurement or manual deletion, it is still held in the data storage until it is called up by the EDV or sent out to a printer.

There is **no** compelling reason to delete the results of individual channels or all channels.  
For some users, however, it may be easier if they can delete the results from a channel that they no longer need, because in doing so the corresponding LED automatically goes out. The user then immediately recognises whether they have already read off sedimentation values (LED dark) or not (green).

Here, each user must individually find a method of operation that is suitable for them.

### Manual deletion of the results in the data storage



There is no function available to the user to delete the results of the data storage. This is reserved for the service functions.

---

## Measurement values

---

The Sediplus® S 200 calculates the sedimentation speed of the erythrocytes and converts the sedimentation range to x mm/1h according to Westergren and/or y mm/2h. All results are shown in the display and can be exported through the RS 232 interface. No additional conversion of the sedimentation values is necessary. The values after 1h correspond to the values according to Westergren.

An evaluation after 2h is also possible in the Sediplus® S 200. In this case, as with the sedimentation system in Westergren tubes, it must be taken into consideration that the increase of sedimentation in the second hour is slower with higher sedimentation values than in the first hour.



- Always note identification numbers together with the patient details in order to maintain a clear arrangement of the diagnosis data.
- Log room temperature with the results in order to be able to clearly evaluate the sedimentation values attained.
- Observe that deviations from the recommended working temperature (see technical data) can significantly change the sedimentation values.
- Also observe disturbance factors described in the technical literature e.g. paraproteinaemia, lipaemia, haemolysis, significantly increased leukocyte level, e.g. during CLL (chronic lymphocytic leukaemia), that can have an influence on the measurement of the blood sedimentation and, if necessary, check the plausibility of the measurement results with unusual blood samples.
- Check the functionality of the sedimentation device at regular intervals, in which you compare the sedimentations evaluated with the sedimentation values read from the scale. Should you determine large deviations, we recommend having the device inspected.

**Examples of technical literature**

---

- 1) German Norm, haematology, DIN 58935-1  
Determination of the erythrocyte-sedimentation speed in blood  
Part 1: Selected method, December 1997.
- 2) British Standard Specification for Westergren tubes and support for the measurement of erythrocyte sedimentation rate, BS 2554:1987.
- 3) L. Thomas: Labs and Diagnosis. 5th Edition.  
Die Medizinische Verlagsgesellschaft Marburg 1998.
- 4) Methods for the Erythrocyte Sedimentation Rate (ESR) Test – 4th Edition; Approved Standard.  
NCCLS Document H2-A4, 2000.

## 8. LIS / Printer connection

The SARSTEDT Sediplus® S 200 is equipped with a serial interface RS232. A lab LIS, the Sediplus® Data-Manager, or a printer with serial interface can be electively connected to this interface.

The connection between Sediplus® S 200 and an IBM compatible PC can be made with a normal, standard 1:1 interface extension cable. The Sediplus® S 200 provides a 9-pole SUBD socket on the back side of the device.

The necessary connection for the data flow control of the control lines RTS/CTS is already provided internally in the SARSTEDT Sediplus® S 200.

For connection with other instruments a corresponding cable must be used. Refer to technical data of the instrument to be connected.

The SUBD socket of Sediplus® S 200 is wired as follows:

- 2 TXD
  - 3 RXD
  - 6 DSR
  - 7 RTS
  - 8 CTS
- 

For transferring the data no action on the part of the user is required. The connected device forwards the available data in the Sediplus® S 200 by activating its RTS line and stops the transfer by deactivating this line, if the option "Flow contr." is set to *RTS/CTS*. If the option is set to *NONE*, the result data is transferred immediately after it is available.

The measurement results in the data storage are only deleted when they are completely transferred to the LIS, the Data-Manager, or the printer. If the device is switched off, this data set is completely transferred again after switching the device on, as long a data set was not completely transferred.

The LIS interface is pre-set with the following transfer parameters, which can be partially changed with the aid of the device configuration.

Parameter	Value	Alternatives
Baud rate	9600	2400, 4800, 9600, 19200
Data bits	8	none
Parity	None	none
Stop bits	1	2
Data format	formatted	compact
Data flow control	RTS/CTS	NONE

Analogously to older Sediplus® S 200 devices, the data is transferred through the RS232 interface in **formatted** form. That has the advantage that the data is represented in an easily-read tabular form in the readout on a printer.

Alternatively, the data can also be transferred in compact form, bounded by STX and ETX.

You can choose between the two data formats in the device configuration.

The data blocks of the two data formats are described in the following:

### Data formatted:

The data is transferred line-by-line in ASCII format. A total of 7 lines are sent per data set, each completed with CRLF.

The lines are composed as follows:

Line	Content	Remark	Length [byte]
1	C L R F	Blank line	2

2	$C_{r f}^L$	Blank line	2
3	.....ID-No. .... $C_{r f}^L$	6 blank spaces at the beginning of the line	26
4	$C_{r f}^L$	Blank line	2
5	.....Pos. .yy $C_{r f}^L$	6 blank spaces at the beginning of the line	15
6	.....60.min. ....aaa.mm $C_{r f}^L$	6 blank spaces at the beginning of the line	24
7	.....120.min. ....bbb.mm $C_{r f}^L$	6 blank spaces at the beginning of the line	24

Total length of the data set = constant = 95 characters

**Data compact:**

The data is transferred as a string in ASCII format. The string begins with the control character STX and ends with the control character ETX. No additional control characters apart from STX and ETX are used. The string is composed as follows:

$S_{t_x}$ .....xyyaaaabbbb $E_{t_x}$

Place holder	Meaning	Number of characters	Offset in the String
$S_{t_x}$	Start of text (Hex 02) Beginning of the data block	1	0
.....	Alphanumeric ID number, right-aligned	12	1
yy	Numeric channel number, right-aligned	2	13
aaaa	Sedimentation value after 1h, alphanumeric	4	15
bbbb	Sedimentation value after 2h, alphanumeric	4	19
$E_{t_x}$	End of text (Hex 03) End of the data block	1	23

**Key (applies for both formats):**

Place holder	Meaning
$S_{t_x}$	Start of text (Hex 02)
$E_{t_x}$	End of text (Hex03)
$C_{r f}^L$	New line (2 characters Hex 0D0A)
.....	ID number (12-digit alphanumeric), right-aligned
yy	Channel number (2 characters, numeric without leading 0)
aaaa	Sedimentation value after 1h (4 characters, numeric without leading 0) Special cases: ">110" = Sedimentation is accomplished " NP!" = Result is implausible
bbbb	Sedimentation value after 2h (4 characters, numeric without leading 0) Special cases: ">110" = Sedimentation is accomplished " NP!" = Result is implausible " " = No 2h result available (BSS mode fast).
.	Blank space (Hex 20)

**ATTENTION:**

In line 3 of the formatted data set there is an incompatibility to earlier devices that only support a 4-digit numeric ID number. In order to practicably configure the entry through the keyboard and/or barcode reader, this field was expanded to 12 alphanumeric characters.

In lines 6 and 7 the sedimentation results are displayed in 4-digits in order to be able to carry out a better differentiation between implausible results (NP!) and accomplished sedimentations (>110). With the older machines the sedimentation result was always displayed numerically in 3 digits. Implausible or accomplished sedimentations were designated by the value **120**.

The complete data format did not exist with earlier devices.

## 9. Device configuration

In order to adapt the SARSTEDT Sediplus® S 200 to the requirements of the user, there is the possibility of putting configuration data in the NV RAM.

The following settings can be used (**bold** = standard setting):

Parameter	Options	Remark
Language	<b>Deutsch</b> English	Language of the text output in the display.
BSS mode	1h <b>1h / 2h</b>	Measurement is finished after 1h Measurement is finished after 2h
Baud rate	2400 4800 <b>9600</b> 19200	Transfer speed of the LIS connection to baud.
Stop bits	<b>1</b> 2	Number of stop bits of the LIS connection.
Data format	<b>formatted</b> compact	Formatted output of the data for the printed readout. Compact output for pure LIS connection. See LIS / Printer connection.
Flow control	<b>RTS</b> NONE	Data flow control. See LIS / Printer connection.
max. underfilling	5mm – <b>15mm</b> in 1mm increments	Maximum tolerated underfilling of the S-Sedivette®.
Frequency of the signaller	<b>1000 Hz</b> – 2000 Hz in 125 increments	The volume perception of the acoustic signal depends heavily on the frequency provided and the individual hearing of the user. The frequency of the signaller can be adjusted here to the subjective perception of the user. To change: Button [1] = lower frequency Button [2] = higher frequency

In order to get into the set-up mode for the device parameters, press the buttons [1] and [2] while switching on, and hold them down until the following display appears:

P	a	r	a	m	e	t	e	r								
---	---	---	---	---	---	---	---	---	--	--	--	--	--	--	--	--

After 1 sec the following automatically appears

S	p	r	a	c	h	e		d	e	u	t	s	c	h		
---	---	---	---	---	---	---	--	---	---	---	---	---	---	---	--	--

With the button [9] you can now select between the individual parameters. You can change the currently displayed parameter with the button [10]. All changes are effective immediately. If the language parameter is changed, all of the following parameters are displayed in the new language. e.g.:

L	a	n	g	u	a	g	e		E	n	g	l	i	s	h	
---	---	---	---	---	---	---	---	--	---	---	---	---	---	---	---	--

To complete the parameter entry the following functions are available.

- **[ESC] button**  
The entry is finished. All changes undertaken remain in place as long as the device is switched on. After switching off the device, all changes are lost. The device is subsequently ready for normal operation.

	S	2	0	0		V	x	x	.	y	y					
--	---	---	---	---	--	---	---	---	---	---	---	--	--	--	--	--

- **[START] button**  
The entry is finished. The current parameters are saved to the NV RAM and are kept there after switching off and back on again. This display appears for approx. 1 sec:

			V	a	l	u	e	s		s	a	v	e	d	!	
--	--	--	---	---	---	---	---	---	--	---	---	---	---	---	---	--

Afterwards the device is ready again for normal operation.

	S	2	0	0		V	x	x	.	y	y					
--	---	---	---	---	--	---	---	---	---	---	---	--	--	--	--	--



---

## 10. Maintenance and repair

---

### Cleaning

---



**Observe the guidelines for cleaning the device without fail. Improper cleaning or non-adherence to the guidelines can lead to malfunctions!**

- Separate the device from the power supply for cleaning.
- No fluids may penetrate into the device during cleaning.
- Clean the housing parts with a damp cloth. A soapy solution can be used. Carefully dry the device afterwards.
- Never use abrasives, harsh cleaners, or solvents (alcohol excluded).
- Isopropyl can be used with heavy staining.



**Example of a disinfectant:**

For disinfection use a water-based solution:

25 g ethanol 96 %, 35 g 1-propanol, 0,1 g glyoxal ad 100 g distilled water.

Apply solution and allow it to work for a few minutes depending on contamination. If necessary repeat wetting with the disinfection solution.

---

### Maintenance intervals

---



It is recommended to have the SARSTEDT Sediplus® S 200 serviced by the manufacturer on an annual basis.

To do so, contact your responsible SARSTEDT Service Organisation or your local SARSTEDT dealer.

**Simple functional checks by the user**

With the aid of a so-called "Position test" the user can test the function of their device to a limited extent on their own. The test tool SediTest S 200 (SARSTEDT item number 92.189.915) is required for this.

**Execution:**

Switch off the device and hold down the button [10] while switching back on until the following display appears:

P	o	s	i	t	i	o	n		t	e	s	t			
---	---	---	---	---	---	---	---	--	---	---	---	---	--	--	--

Now place the SediTest S 200 in one of the channels 1 thru 10 and press the corresponding channel button. The device scans the test tool in the corresponding channel. The following message appears:

C	h	a	n	n	e	l		x	x		T	e	s	t	
---	---	---	---	---	---	---	--	---	---	--	---	---	---	---	--

xx= Channel number.

Afterwards the result is shown in the display.

T	r	a	n	s	i	t	i	o	n	:			0	m	m
---	---	---	---	---	---	---	---	---	---	---	--	--	---	---	---

The target value is 0 mm. A deviation of +/- 1 mm is acceptable.



You can repeat the test as often as you wish, however it should be carried **at least once per measurement channel** in order to check all channels. To do so, place the SediTest S 200 in another channel and press the corresponding channel button.

The following functions are tested:

- The drive of the measuring head over the entire path of travel
- The analogous measurement value entry is checked purely qualitatively for "functions" / "does not function".  
**It is not a quantitative inspection of the measuring sensitivity.**
- The function of the channel switching.  
In doing so it is important to always use 1 single SediTest S 200 in the device. With the use of multiple SediTest S 200 an error in the channel switching may not be recognised.

To finish the test press the [ESC] button. After the measuring head is moved to its starting position the device is ready again for normal operation.

	S	2	0	0		V	X	x	.	y	y				
--	---	---	---	---	--	---	---	---	---	---	---	--	--	--	--

## Troubleshooting

In order to avoid operating errors or to independently recognise device errors, the SARSTEDT Sediplus® S200 carries out the following checks during its run time:

**Check for operating errors:**

- Correct fill level of the S-Sedivette®
- Correct placement of the label
- Availability of the desired measuring channel
- Functionality of the desired measuring channel

**Check for malfunctions:**

- Monitoring of the motor drive for step loss
- Check for power failure

**Check for data integrity:**

- Monitoring of all saved data in the NV RAM for correct check sums

As a result the following error messages may arise:

Message	LED / Signaller	Reason	Measure(s)
<b>Power failure!!</b> immediately after switching on	1 or several LEDs blinking red. Continuous tone	During a measurement the device was switched off or a power failure occurred. The measurements on the affected channels are lost	Press [ESC] button. The device can be operated again.
<b>xx Power failure</b> xx= Channel no.	LED xx blinks red	The selected channel was affected by a power failure.	The channel can be used again. The LED goes out after the new start of a measurement or can be turned off with the button [ESC].
<b>Drive defect !</b>	Continuous tone	Step loss of the measuring head drive.	The device cannot be operated again. Switch off and switch on again. If the message remains notify Service.
<b>xx Drive error</b> xx= Channel no.	LED xx green	No results are present at the selected channel because a drive error was recognised while measuring.	Scan the results of all channels and notify Service.

<b>Config. error!</b> immediately after switching on.	Continuous tone	An error of the data integrity was detected. The device can no longer be operated.	Notify Service. The user can no longer start the device.
<b>Channel defect!</b>	No change	You have attempted to start a measurement that is marked as defective.	All other channels can continue to be operated. Notify Service.
<b>Channel occupied!</b>	No change	You have pressed the button of an occupied channel for starting a measurement.	Select the correct channel.
<b>All ch. occupied</b>	No change	You have pressed the [START] button, but all channels are occupied.	Wait until a channel becomes free.
<b>xx Underfilled</b> xx= Channel no.	3 Whistle tones	The tube is not sufficiently filled.	Request new material. The measurement is interrupted.
<b>xx Overfilled</b> xx= Channel no.	3 Whistle tones	The tube is overfilled.	Request new material. The measurement is interrupted.
<b>xx Label too high</b>	3 Whistle tones	The label is placed too high on the tube	Peel off label and reapply, if possible. The measurement is interrupted.
<b>xx No sample</b>	3 Whistle tones	You have not placed a sample in the selected channel.	The measurement is interrupted. Insert sample and start again.

**Service address**

If you should have questions or problems with the device, contact the service department of DESAGA GmbH / SARSTEDT-GROUP in Wiesloch or your local SARSTEDT dealer. Be sure to provide the serial number of the device.



**DESAGA GmbH / SARSTEDT-GROUP**  
Service department  
Ziegelwiesen 1-7

**D-69168 Wiesloch**

**Tel.: +49 (0) 62 22 / 92 88 65**  
**Fax.: +49 (0) 62 22 / 92 88 60**



- Fill out contamination questionnaire (see the end of the operating instructions) and accompany with a copy of the delivery note and a brief explanation of the problems that have arisen with the device.
- Always send the device in the original packaging. If this is no longer available, then substitute packaging must be used to prevent damage to the device during transport. Responsibility lies with the sender.
- The contamination questionnaire serves for the security of our service employees. Please fill it out as carefully as possible in order to avoid delays to the repair work.

## 11. Glossary

<b>Anticoagulant</b>	Material for inhibiting clotting Sodium citrate solution (0.106 mol/l), 0.7 ml pre-dosed in the S-Sedivette®.
<b>ASCII-Code</b>	American Standard Code for Information Interchange.
<b>Blood cell sedimentation speed</b>	Erythrocyte sedimentation rate (ESR) in x mm/h.
<b>Channel button</b>	Buttons of the Sediplus® S200 that correspond to the individual measuring points. The buttons are labelled with the numbers 1-10.
<b>CR LF</b>	2 characters of the ASCII code table for representation of the end of a line CR=Carriage return; LF=Line feed. Is used in combination with a barcode reader as simulation of the conclusion of an entry (e.g.: <ENTER> button).
<b>Data storage</b>	Electronic module for saving the measurement results.
<b>ESR</b>	Erythrocyte (red blood cell) sedimentation rate
<b>ETX</b>	A line of the ASCII code table for designation of the end of a data block. ETX = End of text. See also STX.
<b>FIFO principle</b>	<b>First In First Out.</b> Sequence of storage and calling up data from data storage.
<b>ID Number</b>	Identification number of a sample.
<b>IBM keyboard with PS/2 plug</b>	Entry keyboard, is used in the same manner as with common PCs.
<b>LIS</b>	<b>Laboratory Information System</b>
<b>Measuring head</b>	Vertically-moving part of the Sediplus® S200 for the assimilation of sensors that scan the Sedivettes placed in the device from bottom to top in order to determine the sedimentation value.
<b>Measuring point</b>	One of 10 different sample retainers for the S-Sedivette®. Is also often designated in the document as measuring channel.
<b>NV RAM</b>	Data storage that does not lose its contents after switching off the device. No batteries are necessary for securing the data.
<b>NP!</b>	Designation of an implausible measurement value. NP! = not plausible!! Samples whose measurement result is marked with NP! could not be analysed properly by the device!
<b>RTS/CTS</b>	Lines of the RS232 interface for control of the data transfer between devices. See also RS233 interface.
<b>Serial interface RS232</b>	Serial electronic communications interface according to the Standard RS232 or EIA 232.
<b>STX</b>	A line of the ASCII code table for designation of the beginning of a data block. STX = Start of text. See also ETX.
<b>Working temperature &gt;110</b>	18 °C to 23 °C, or depending on the national/lab-specific determination Designation of a clearly "accomplished" sedimentation.

**Contamination questionnaire  
with repair orders**

**Dear valued customer,**

We request that you answer all of the following questions for safety reasons before you send your device to DESAGA GMBH / SARSTEDT-GROUP Wiesloch maintenance, repair, or return.

Company: _____	Department: _____
Location: _____	Street: _____
Name: _____	Telephone no.: _____
Device/article: _____	SN: _____

The device is free of hazardous materials

The device came into contact with the following hazardous materials

	Material class	Material designation
<input type="checkbox"/>	Caustic materials	
<input type="checkbox"/>	Easily flammable materials	
<input type="checkbox"/>	Environmentally hazardous materials	
<input type="checkbox"/>	Poisonous materials	
<input type="checkbox"/>	Health-threatening materials	
<input type="checkbox"/>	Radioactive materials	
<input type="checkbox"/>	Bio-hazardous materials	
<input type="checkbox"/>	Other materials	
<input type="checkbox"/>	The device was decontaminated according to the legal guidelines.	

(Please cross applicable)

Description of the decontamination implemented:

Date: _____	Signature: _____
-------------	------------------